

1300-029

# INSTRUCTION, **DART**<sup>™</sup> AIR PRESSURE CHECK

REV	DATE	EC#	DESCRIPTION	DRAWN	CKD
A	2022-04-20		ORIGINATED	JMA	CED

1300-029 INSTRUCTION, DART AIR PRESSURE CHECK



# INSTRUCTION AIR PRESSURE CHECK

## STEP 1: AIR PRESSURE CHECK

- Disconnect tube in location shown (air output on enclosure)
- Install in-line gauge at air output to actuator
- Operate switch and observe air pressure.
  - If pressure is maintained > 80 psi is observed while operating the switch
    - See document 1300-028 (voltage check)
  - If no pressure is observed while operating the switch
    - See document 1300-028 (voltage check)
    - If voltage check is sufficient and no air pressure is observed on output, enclosure must be replaced
  - If pressure is low (> 0 and < 80 psi),
    - Confirm vehicle supply pressure is > 80 psi
      - If pressure adequate, replace Pressure Protection Valve at tank
      - If pressure is still low on output of enclosure, replace enclosure assembly
    - If vehicle supply pressure is < 80 psi
      - Fix supply pressure issues on vehicle
      - Recheck enclosure output pressure (restart this guide)

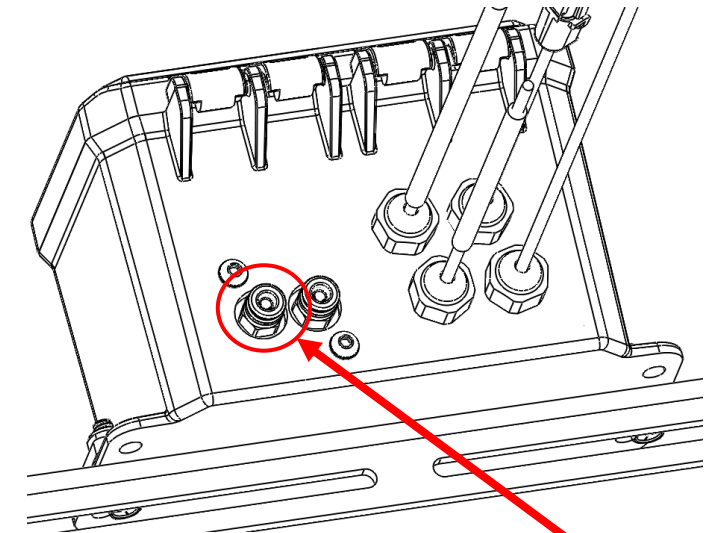

Disconnect tube and check air here (AIR OUTPUT)

